



# DirectoValve® B Style Electric Motors and Valves

## Shutoff/Control Motors

Boom Control motors are 22 RPM for 344B series (0.7 second shutoff valves) and 25 RPM for 346B and 356 series (0.6 second shutoff valves) for 12 VDC systems. Available with E or EC series motors with DIN or CABLE versions. E type motors work with DPDT (double pole, double throw) switch. EC type motors work with simple SPST (single pole, single throw) on/off switch and are compatible with all sprayer controls.

Current draw less than 2 amps (1.7 amps at 40 in.-lbs.).

Electrical connectors can be ordered with a standard number. See page 117 for more information.

**Note:** 2-way control motors can be rotated 180° to change the cable outlet direction on the valve. There is also an adapter to rotate motors 90°, contact your local representative for more information.

An internal fuse protects the valve and your electrical system, and it resets automatically by disconnecting power to the motor for 20 seconds.

Direct coupled visual indicator to verify position/operation. Yellow oval indicates 22 RPM motor. Yellow diamond indicates 25 RPM motor.

Cover fits snugly over the motor cavity to reduce air space and eliminate condensation. It's sealed and sonically welded to comply with the IP67 rating for submersion under water.

Permanent etched marking with complete motor number and date coded (year, month, day).

Double-wall construction of the gearbox increases strength and maintains permanent lubrication of the durable, all-metal gears.

Motor head assembly is easily detached by pulling a retaining pin allowing manual operation or easy replacement of the motor.

Available for either positive or negative switched electrical systems with a sturdy, built-in double sealed grommet and flat gasket that seals the DIN connector versions. Motor and DIN cables are made of polyurethane.



## Regulating Motors

Choosing the proper regulating motor speed is important to maximizing the sprayer's performance. Three speeds are offered at this time: 1 RPM, 3 RPM and 6 RPM. The 1 RPM speed is used mostly in manual systems; it is too slow for automated rate control. The other two speeds are used in automated systems. The 3 RPM is the most popular and opens the valve to the maximum flow in about 6 seconds for the RL valve and about 10 seconds for the PR valves. The 6 RPM motor cuts those times in half.

## DIN and Cable Electrical Connector

Both DIN and motor cables are made of polyurethane and are pressure extruded creating a round cable for improved sealing. Polyurethane has twice the strength and three times the tear and abrasion resistance of PVC. Motor cables include over-molded plugs that seal off the ends of cables and wires to prevent seepage. Conductor insulation uses familiar color coding of red, white and black.

DIN cable connectors are constructed of a special over molded elastomeric material that does not require a flat gasket to be sealed. The center screw is made of stainless steel.

## How to Order:

Example: 38082-30, 10 ft. (3 meter) DIN cable.



DIN CABLE	CABLE
38082-05	1.5' (0.5 meter) DIN cable
38082-15	5' (1.5 meter) DIN cable
38082-30	10' (3 meter) DIN cable
38082-60	20' (6 meter) DIN cable

DIN cables are ordered separately.

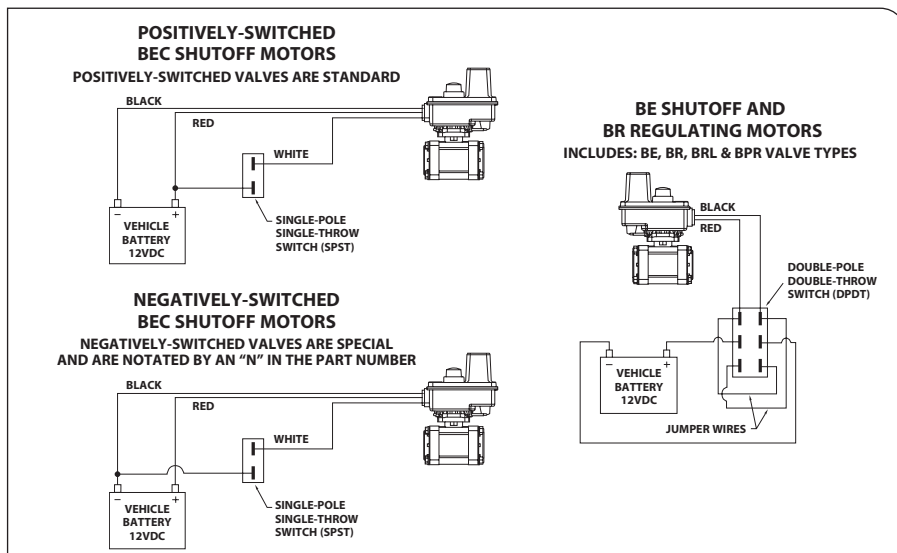



## B Style Shutoff Motor Numbers

344B, 440B, 450B, 460B SERIES			CURRENT DRAW (AMPS)**	346B, 356 AND 490 SERIES			CURRENT DRAW (AMPS)**		CABLE LENGTH
BEC POSITIVE SWITCH MOTOR	*BEC NEGATIVE SWITCH MOTOR	BE SWITCH MOTOR	344B, 440B, 450B, 460B	BEC POSITIVE SWITCH MOTOR	*BEC NEGATIVE SWITCH MOTOR	BE SWITCH MOTOR	346B	356, 490	
50515-22CP03	* 50515-22CN03	* 50533-22C03	1.1	50515-25CP03	* 50515-25CN03	* 50533-25C03	1.75	2.2	1.0' (0.3 meter) cable
50515-22CP05	* 50515-22CN05	50533-22C05	1.1	50515-25CP05	* 50515-25CN05	50533-25C05	1.75	2.2	1.5' (0.5 meter) cable
50515-22CP15	* 50515-22CN15	* 50533-22C15	1.1	50515-25CP15	* 50515-25CN15	* 50533-25C15	1.75	2.2	5' (1.5 meter) cable
50515-22CP60	* 50515-22CN60	* 50533-22C60	1.1	50515-25CP60	* 50515-25CN60	* 50533-25C60	1.75	2.2	20' (6 meter) cable
50515-22DP	* 50515-22DN	* 50533-22D	1.1	50515-25DP	* 50515-25DN	* 50533-25D	1.75	2.2	DIN Electrical Connector

Items marked with "\*" are non-stock items.

\*\* Current draw is a nominal rating @ 13.8 VDC and will vary dependent upon valve usage and chemicals used.

**Note:** DIN cables are ordered separately.

## \*Bypass Valve (Normally Open) BEC Motors

344B, 440B, 450B, 460B SERIES			CURRENT DRAW (AMPS)**	346B, 356 AND 490 SERIES			CURRENT DRAW (AMPS)**		CABLE LENGTH
BEC POSITIVE SWITCH MOTOR	*BEC NEGATIVE SWITCH MOTOR	BE SWITCH MOTOR	344B, 440B, 450B, 460B	BEC POSITIVE SWITCH MOTOR	*BEC NEGATIVE SWITCH MOTOR	BE SWITCH MOTOR	346B	356, 490	
50994-22CP03	* 50994-22CN03	* 50533-22C03	1.1	50994-25CP03	* 50994-25CN03	* 50533-25C03	1.75	2.2	1.0' (0.3 meter) cable
50994-22CP05	* 50994-22CN05	50533-22C05	1.1	50994-25CP05	* 50994-25CN05	50533-25C05	1.75	2.2	1.5' (0.5 meter) cable
50994-22CP15	* 50994-22CN15	* 50533-22C15	1.1	50994-25CP15	* 50994-25CN15	* 50533-25C15	1.75	2.2	5' (1.5 meter) cable
50994-22CP60	* 50994-22CN60	* 50533-22C60	1.1	50994-25CP60	* 50994-25CN60	* 50533-25C60	1.75	2.2	20' (6 meter) cable
50994-22DP	* 50994-22DN	* 50533-22D	1.1	50994-25DP	* 50994-25DN	* 50533-25D	1.75	2.2	DIN Electrical Connector

Items marked with "\*" are non-stock items.

\*\* Current draw is a nominal rating @ 13.8 VDC and will vary dependent upon valve usage and chemicals used.

**Note:** DIN cables are ordered separately.

## 344B & 346B Regulating Motors

SPEED (RPM)	R & RL MOTOR NO.	PR MOTOR NO.	CURRENT DRAW (AMPS)**		CABLE LENGTH
			AA344B	AA346B	
1	* 50516-01C03	* 50996-01C03	0.10	0.12	1.0' (0.3 meter) cable
1	* 50516-01C05	* 50996-01C05	0.10	0.12	1.5' (0.5 meter) cable
1	* 50516-01C15	* 50996-01C15	0.10	0.12	5' (1.5 meter) cable
1	* 50516-01C60	* 50996-01C60	0.10	0.12	20' (6 meter) cable
1	* 50516-01D	* 50996-01D	0.10	0.12	DIN Electrical Connector
3	* 50516-03C03	* 50996-03C03	0.15	0.20	1.0' (0.3 meter) cable
3	* 50516-03C05	* 50996-03C05	0.15	0.20	1.5' (0.5 meter) cable
3	* 50516-03C15	* 50996-03C15	0.15	0.20	5' (1.5 meter) cable
3	* 50516-03C60	* 50996-03C60	0.15	0.20	20' (6 meter) cable
3	* 50516-03D	* 50996-03D	0.15	0.20	DIN Electrical Connector
6	* 50516-06C03	* 50996-06C03	0.43	0.50	1.0' (0.3 meter) cable
6	* 50516-06C05	* 50996-06C05	0.43	0.50	1.5' (0.5 meter) cable
6	* 50516-06C15	* 50996-06C15	0.43	0.50	5' (1.5 meter) cable
6	* 50516-06C60	* 50996-06C60	0.43	0.50	20' (6 meter) cable
6	* 50516-06D	* 50996-06D	0.43	0.50	DIN Electrical Connector

Items marked with "\*" are non-stock items.

\*\* Current draw is a nominal rating @ 13.8 VDC and will vary dependent upon valve usage and chemicals used.

**Note:** DIN cables are ordered separately. See page 78 for DIN cable options.



# DirectoValve® 450 Series Shutoff Manifold

450BEC manifolds are available with E or EC series motors with cable or DIN electrical connections. See page 78 for more information on DirectoValve motors.

## Features:

- 22 RPM, 0.7 second shutoff fully open to close.
- Available in 2-way and Flow Back versions. Pressure regulating valves can be incorporated.
- Flexible inlet/outlet connections allow for quick, simple plumbing for as many valves as needed for your sprayer.
- Stainless steel stem with optional polypropylene or stainless steel ball.
- Maximum pressure rating of 200 PSI (14 bar).
- The flow rate for the 450BEC 2-way valve is 32 GPM (121 l/min) with 5 PSI (0.34 bar) pressure drop, 45 GPM (170 l/min) with 10 PSI (0.69 bar) pressure drop.
- Wetted parts are Nylon, Teflon®, polypropylene and Viton®.



**451BEC-2F-C Valve**  
(rear view)



(front view)



**453BEC-24-C Manifold**  
(rear view)

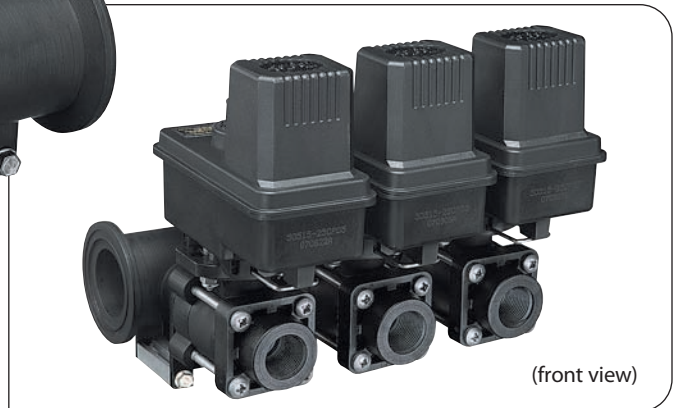

(front view)



### Sample Valve Part Number:

# (B)453BEC-2FS-CN15AB

#### OUTLET THREADS

PART CODE	DESCRIPTION
BLANK	ALL THREADS TO BE NPT (IF EQUIPPED)
(B)	ALL THREADS TO BE BSPT (IF EQUIPPED)

#### MODEL SPECIFICATION

PART CODE	DESCRIPTION
45	450 MANIFOLD

#### MANIFOLD SIZES

PART CODE	DESCRIPTION
1	1-VALVE MANIFOLD
2	2-VALVE MANIFOLD
3	3-VALVE MANIFOLD
4	4-VALVE MANIFOLD
5	5-VALVE MANIFOLD

#### MOTOR SPECIFICATIONS

PART CODE	SWITCH	DESCRIPTION
E	DPDT	22 RPM, 0.7 SECOND SHUTOFF VALVE
EC	SPST	

#### VALVE TYPE

PART CODE	DESCRIPTION
2	2-WAY VALVE
2N	2-WAY VALVE, NARROW

**Note:** 3-way valve type not available on 450 manifold.

#### END CAPS OR OUTLET FITTINGS

PART CODE	DESCRIPTION
3	¾" PIPE THREAD
4	1" PIPE THREAD
Q	QUICK CONNECT
F	50 SERIES FLANGE

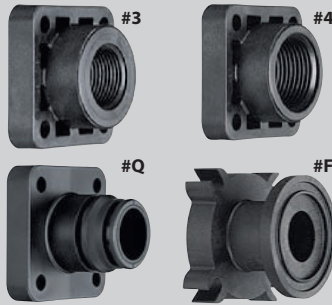

#### WIRING CONNECTORS

SPECIFY ELECTRICAL CONNECTOR STYLE AND PIN-OUTS. IF NO CONNECTOR IS NEEDED LEAVE BLANK.

See page 117 for electrical connectors and codes.

#### MOTOR CABLES

PART CODE	DESCRIPTION
C	POSITIVELY SWITCHED w/ 0.5-METER CABLE
CN	NEGATIVELY SWITCHED w/ 0.5-METER CABLE
* C03	POSITIVELY SWITCHED w/ 0.3-METER CABLE
* CN03	NEGATIVELY SWITCHED w/ 0.3-METER CABLE
* C15	POSITIVELY SWITCHED w/ 1.5-METER CABLE
* CN15	NEGATIVELY SWITCHED w/ 1.5-METER CABLE
* C60	POSITIVELY SWITCHED w/ 6.0-METER CABLE
* CN60	NEGATIVELY SWITCHED w/ 6.0-METER CABLE
D	POSITIVELY SWITCHED w/ DIN CONNECTOR
DN	NEGATIVELY SWITCHED w/ DIN CONNECTOR

Items marked with "\*" are non-stock items. Please contact your regional sales office for ordering and availability information.

**Note:** DIN cables must be ordered separately. See page 78 for DIN cables.

#### INLET/OUTLET REQUIRED CONNECTIONS

THE INLET/OUTLET FITTINGS ARE ORDERED SEPARATELY

- **3, 4:** When ordering ¾" (3) or 1" (4) NPT or BSPT threaded connections, the valve outlet connection will be completed during the ordering process. For the inlets, the 75 series flange fittings are ordered separately. Two 75 series clamps and fittings are required per manifold assembly. See pages 114–115 for flange fitting options.
- **F:** When ordering F (flange) type valve connections, the inlet/outlet fittings are ordered separately. For the outlet, one 50 series clamp and flange fitting is required per valve. For the inlets, two 75 series clamps and flange fittings are required per manifold assembly. See pages 114–115 for flange fitting options.
- **Q:** When ordering QC (Quick Connect) type valve outlet fittings, only the outlets will be QC fittings and are ordered separately. One 45229 QC hose barb connection is required for each valve in the manifold. See page 116 for QC hose barb options. The inlets will be standard 440 connections as described in the ordering process.

**Note:** Many manifold configurations are possible by mixing and matching flange fittings.

#### BALL MATERIAL SPECIFICATIONS

PART CODE	DESCRIPTION
BLANK	POLYPROPYLENE BALL
S	STAINLESS STEEL BALL

#### REPAIR KIT

AB344AE-KIT